



**A cost effective,
energy efficient,
carbon capture solution**

www.co2capsol.com

info@co2capsol.com



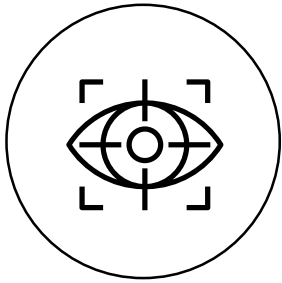

OUR VISION

To accelerate the world's transition to a carbon negative future.

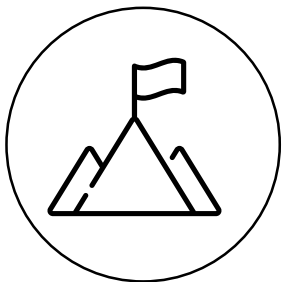

OUR MISSION

Our mission is to be a major contributor to solving one of our biggest global challenges; climate change, with our patented Capsol EoP (End of Pipe) - a cost effective, energy efficient, compact, scalable and flexible retrofit capture carbon solution for power plants and industrial facilities.

**We aim
to be a
global leader
in capturing CO₂
from power plants
and industrial
facilities**



Process overview

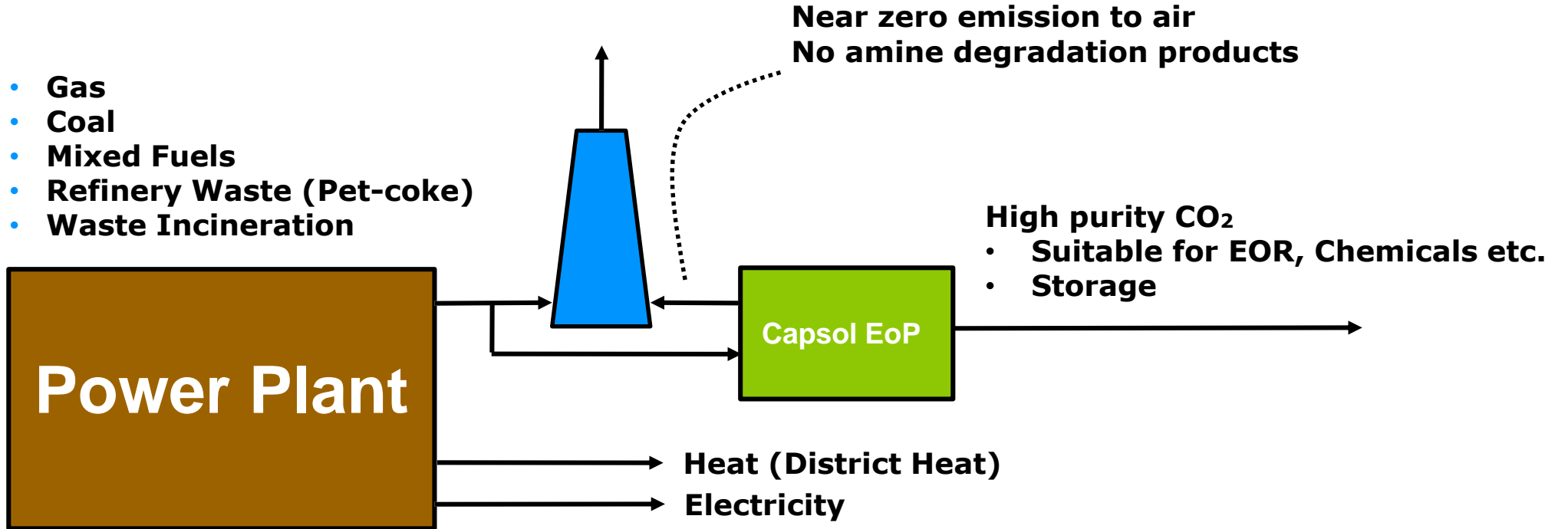

CO₂ Capsol offers a well-proven carbon capture solution based on Hot Potassium Carbonate (HPC) with several competitive advantages compared to Amine based solutions

A unique and very simple set-up designed to keep the energy in the system

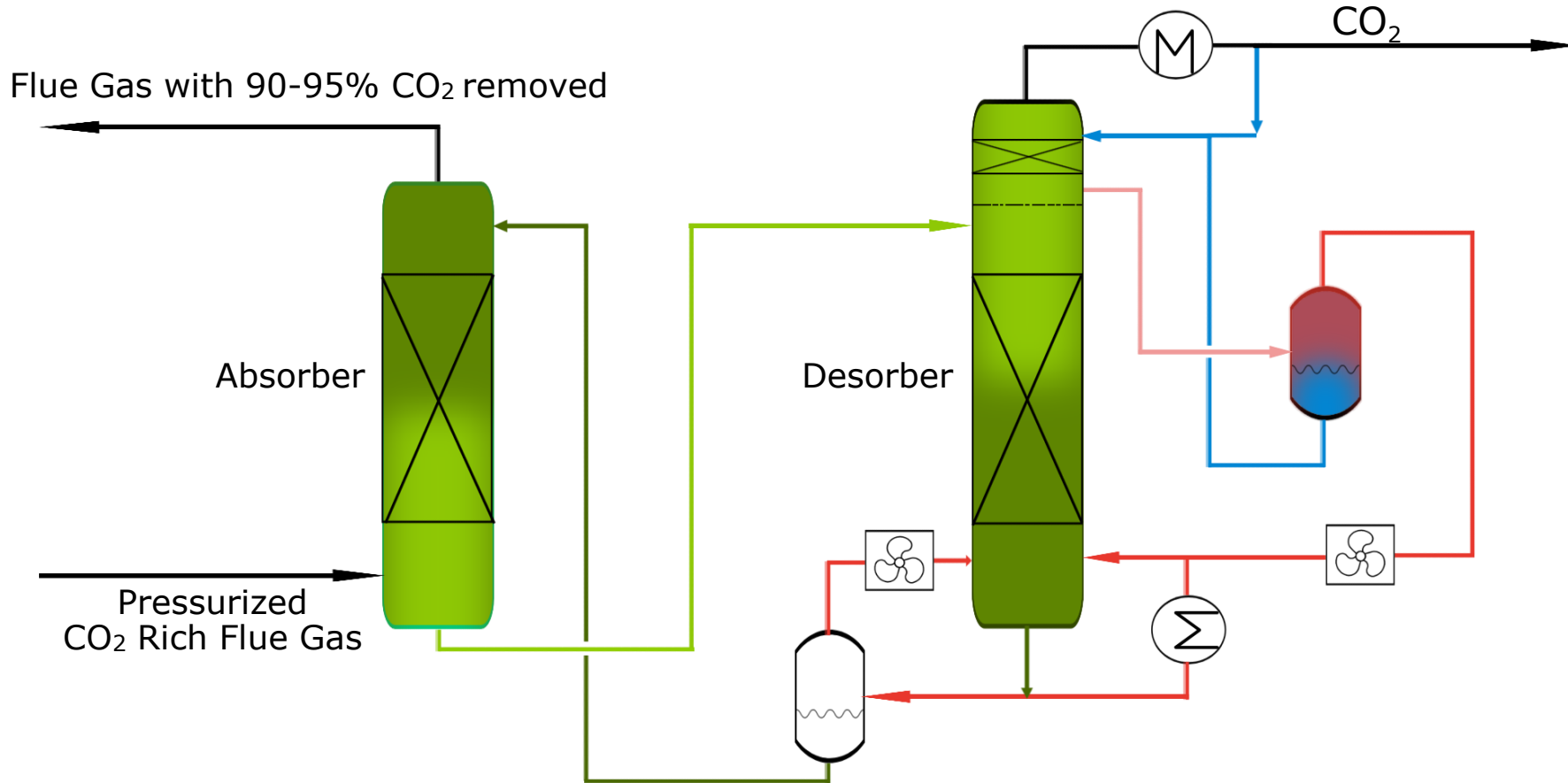

- The HPC technology is widely used in hundreds of plants; **however with significant energy loss**
- CO₂ Capsol has patented rights for energy recirculation; **that significantly improves the HPC process**

Main difference between a traditional set-up without energy saving and Capsol End of Pipe (EoP) is the use of steam recycling in the desorber

Field-Proven Technology

Using HPC (Hot Potassium Carbonate) as an absorbent of flue gas is **thoroughly documented and used in thousands of existing plants.**

The Capsol EoP solution has been **developed and refined during a 15 year period.** Capsol EoP can capture CO₂ from any power plant, industrial facility or plant powered with biofuel.



Inexpensive Absorbent

Hot Potassium Carbonate (HPC) is **significantly more cost effective than Amines.**

Potassium carbonate is a common remedy in the food industry and readily available.



Flexible and Scalable

A single unit can process flue gas from plants with emissions of up to **2.5 million tons/year** with flue gas CO₂ concentrations of 20%.

Two or more units will operate **in parallel** for facilities with emissions of more than 2.5 million tons/year.

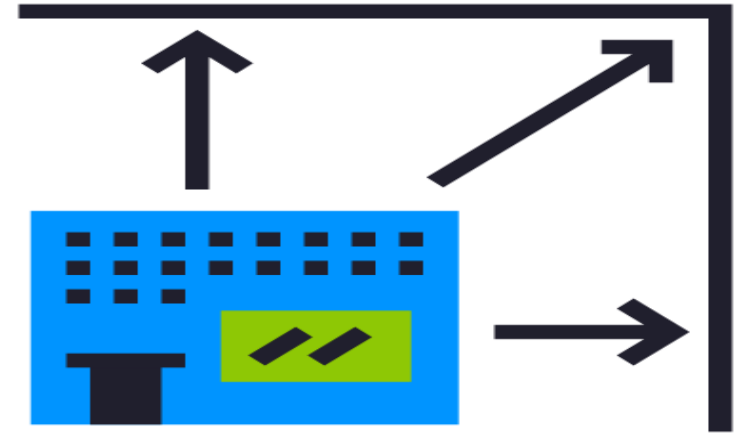

Cost-Efficient

The industry's **most cost-efficient solution** due to **low energy consumption** (200 kWh/ton CO₂ captured (0.7 GJ/ton)) in the capture process, thanks to our **patented energy recuperation**.

For comparison, Amine-based technology requires approximately 2.5 GJ/ton CO₂ captured, mostly in the form of heat.

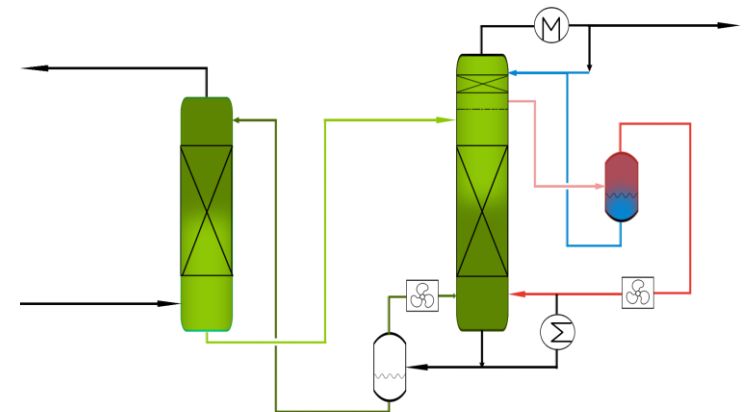

Stand Alone Unit

Easy to install stand-alone unit. **Does not interfere with existing facility.** Compact design. Minimal space requirements. **No downtime during installation period.** Installation and commissioning time of only 24-30 months for large plants.



No Harmful Chemicals

In contrast to alternative solutions, no risk related to emission of harmful chemicals, which is a big advantage of using HPC as absorbent.



Electricity or Steam

The Capsol EoP solution can be **powered by electricity or steam.**

Benefits of being able **to run on electricity only** is

- 1) The capturing facility is independent of the mother plant.
- 2) No need to invest in steam production to run the capture unit.



Results from engineering study by CO2 Capsol in 2020

Study performed on Waste-to-Energy (WtE) plant in Europe.

CO₂ emissions: 300.000-500.000 ton CO₂/year

The **Capsol EoP solution**, using electricity only, gave the following results:

- OPEX: 19 EUR/ton CO₂ captured
- CAPEX: 7–8 EUR/ton CO₂ captured
- **Capture costs: 26-27 EUR/ton CO₂ captured**
- CO₂ Capture rate: 95%

Studies published by [Sintef](#) indicate capture costs of **39–55 EUR/metric ton CO₂-captured** (depending on the cost of external energy) for steel, pulp and paper, and cement, using **Amine based technology**.



Amine based solutions 50% more expensive

A new report issued by the [Swedish Energy Agency](#) on June 18, 2020, shows that carbon capture cost (Capex and Opex) for kraft pulp mills in Sweden are 50% more than our patented Capsol EoP solution (see next slide).

Capsol EoP Capture costs: 25-30 €/ton CO₂-captured

A similar study by [Sintef](#) indicate carbon capture costs of 39–55 €/ton (depending on the cost of external energy) for steel mills, pulp and paper mills, and cement plants, using amine based technology. In comparison, capture costs for Capsol EoP is 25-30 €/ton CO₂-captured, depending on application.

Factors affecting the CO₂ capture costs

Factors affecting the CO₂ capture costs is mainly regional variations in cost of energy and the CO₂-concentration in the flue gas. Flue gas CO₂-concentration varies depending on type of industry/facility.

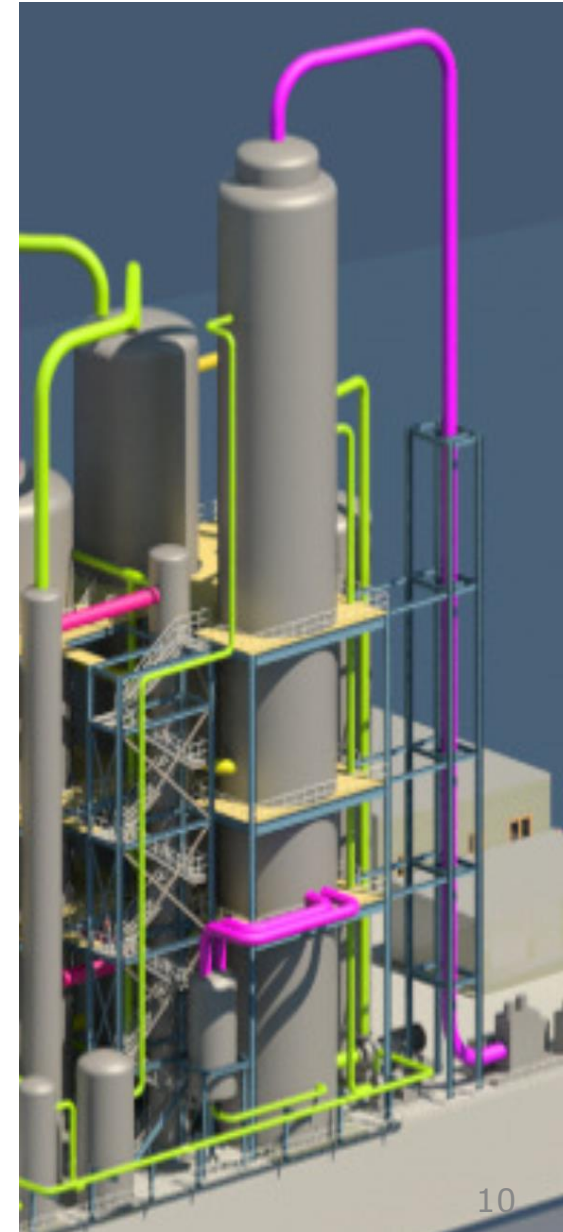

CO2 capture costs (€/ton) ^{*)}

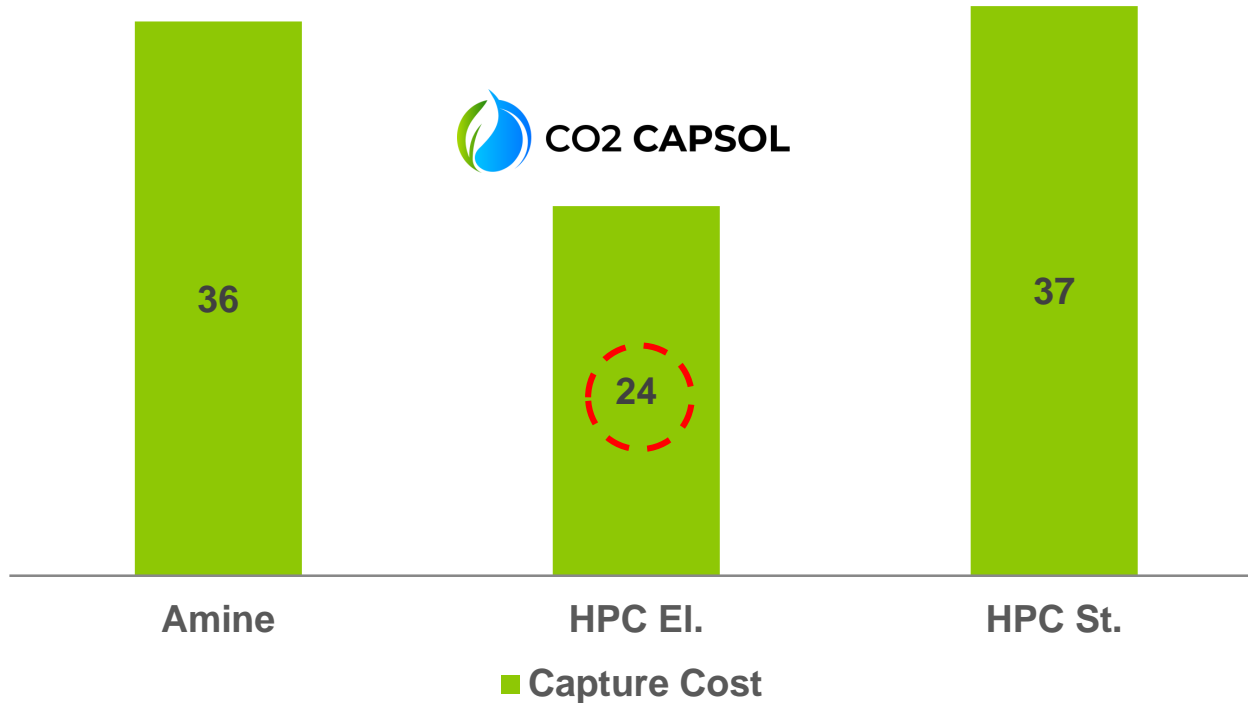

01

Capex lower than competitors

Our estimated Capex will be lower than competitors primarily due to reduced cost for modification/integration of mother plant.

02

Lower/no chemical cleaning costs

We use non-toxic chemicals (absorbent) which reduce capture cleaning costs.

03

Free to choose EPC contractor

We are independent. No exclusive agreement with any EPC contractor. Plant owner can choose EPC contractor with lowest price during tendering process.

HPC (Hot Potassium Carbonate)

- ✓ More than 675 installations using HPC globally
- ✓ Low level of complexity, cost efficient and non-toxic process
- ✓ No hazard to environment or people
- ✓ Less expensive than Amines or Amino acids
- ✓ The captured CO₂ is totally free of degraded (potentially carcinogenic) amines, it has a very low oxygen content and it is suitable for technical use
- ✓ Studies show 50% higher carbon capture costs using Amines compared to our Capsol EoP (HPC) solution
- ✓ Potassium carbonate is readily available and a common remedy used in the food industry

Amines

- High energy consumption
- Chemical reactions can form new compounds such as nitrosamines and nitramines, which can negatively affect health and the environment
- The nitrosamines needs to be collected and treated which is a costly procedure
- Can react with oxygen or NO_x in the flue gases forming corrosive degradation products and nitrosamines which are harmful
- Can be degraded to some extent in the presence of O₂, SO₂, NO₂ and HCl. Makeup is needed to be added which increases OPEX

So why does not everybody use HPC?

Using HPC as absorbent requires pressurized gas for the chemical reaction between CO₂ and HPC to take place. The flue gas in ordinary plants is not pressurized. The flue gas must therefore be pressurized. **This requires large amounts of energy i.e. very expensive.** Our **Capsol EoP solution recycles most of the energy** used for pressurizing the flue gas, thus **making it energy efficient and very cost effective.**

Brief History and Growth Expectations

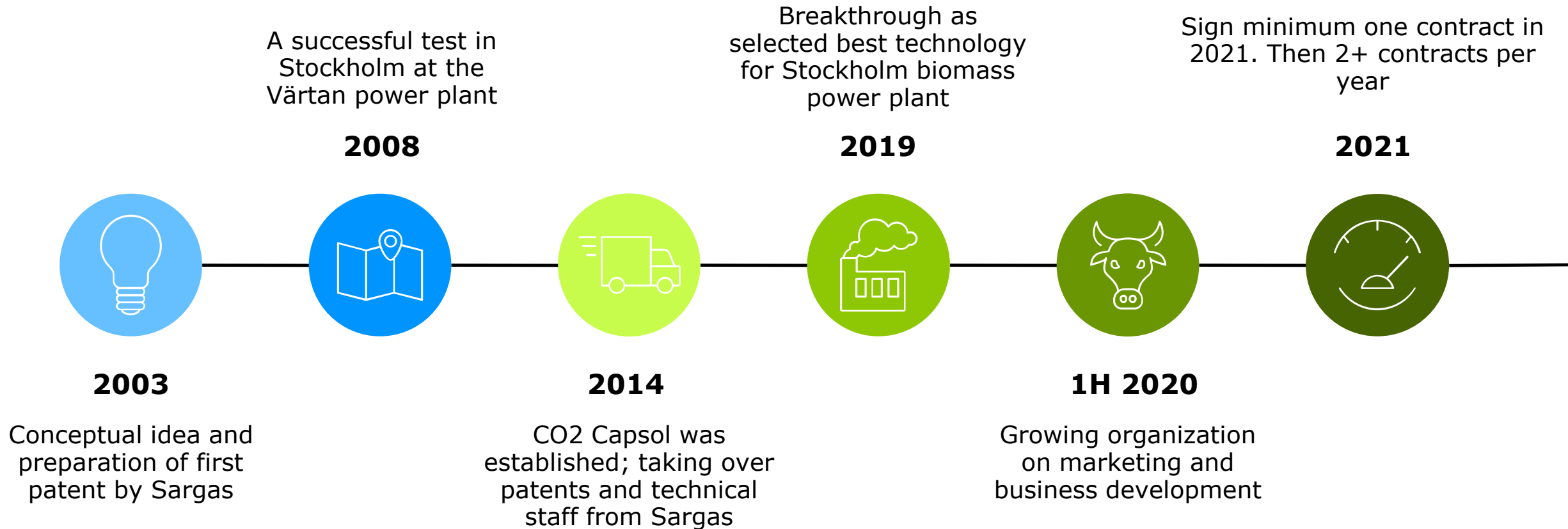

Some of the projects we are involved in:

- 01** | Sweden: Biomass-fired CHP Plant (Combined Heat and Power), Waste to Energy(WtE) plants and kraft pulp mills.
- 02** | Norway: Waste to Energy and industrial plants
- 03** | Europe: Power and Waste to Energy Plants
- 04** | US: Industrial Plants
- 05** | Far East: Partnering with large Engineering Procurement and Construction(EPC) company.



Jan Kielland

CEO

- Various roles at Shell, Saga Petroleum, Lundin Petroleum, Panoro Energy, Clean Carbon Group
- MSc in Petroleum Engineering



Tone Bekkestad

Marketing and Communication Manager

- On-air meteorologist at TV4 Sweden, lecturer, author, various roles at WeatherOne, NILU
- MSc in Meteorology



Marius Firing

Business Development Manager

- MD of Melberg Partners, various roles at DNV, Hydro, Esso Norway, Exxon Mobile
- MSc in Marine Technology

Patent founders / technical expertise:



Eirik Lunde

CFO

- Broad financial and analytical background. KPMG London and Melberg Partners
- MSc from London School of Economics



Tor Christensen

Senior Specialist Engineer

- Leading research positions in oil company, co-founder and partner, developed several patents
- PhD and MSc in Chemical Engineering



Ingvild Ombudstvedt

Legal Advisor

- Extensive experience on legal issues relating to CCS, CCU, CCUS, business development
- Economist and lawyer



Stellan Hamrin

Senior Specialist Engineer

- Developed the Capsol EoP and other patents. Has also worked with other capture technologies
- MSc in Mechanical Engineering

Patent rights in all key regions and within several patent families, each with equal priority and based on the same invention

Thermal power plant with CO₂ sequestration

Entered: 20.02.2008

Duration: 20.02.2029

Heat integration in CO₂ capture

Entered: 28.10.2010

Duration: 28.10.2031

Method and plant for CO₂ capture

Entered: 08.09.2015

Duration: 06.09.2036

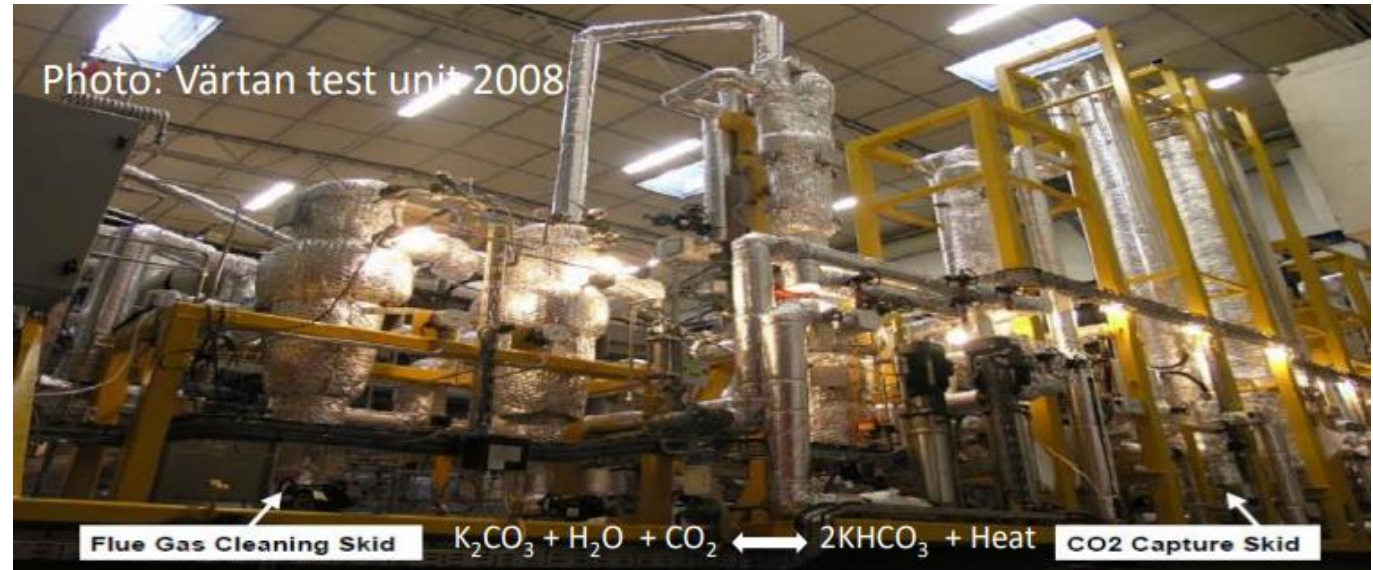

New patents will be filed related to experience from ongoing projects and new opportunities

*For more details, see Appendix page 36

Options

With reference to the Investment Agreement dated 23 December 2020, the investors who participated in the equity issue were granted the following options (on a pro-rata basis):

- (i) to subscribe for shares in the Company with a total subscription amount of NOK 25m to a subscription price of NOK 4.04 per share
- (ii) to subscribe for shares in the Company with a total subscription amount of NOK 25m to a subscription price of NOK 3.23 per share

The share option set out in (i) above must be exercised by written notice to the company by the end of 2021. The share option in (ii) must be exercised by written notice to the Company within 30 days following the company entering into its first license agreement

Warrants

The Company has issued 5 million non-transferrable warrants to the Existing Shareholders prior to the investors participating in the equity issue (on a pro-rata basis)

The warrants shall be exercisable if the 30-day volume-weighted average share price of the Company's shares on a multilateral trading facility or a regulated market, (i) at any time has increased above NOK 9.69 per share and (ii) represents in aggregate more than 5% of the shares outstanding.

If such a reference price is not available, the market price shall be determined based on the last available issue or sales price, or alternatively by an independent valuation committee to be appointed by the Company with the approval of at least 50% of the shareholders in the company who are not existing shareholders. If a valuation committee is not appointed, each party may request the Norwegian Securities Dealers Association to appoint the valuation committee

The warrants' strike price, if exercised, shall be NOK 1 per share

CONTACT US

Contact Person Jan Kielland

 CO2 Capsol AS,
Nobels gate 10, 0273 Oslo, Norge

 +47 415 69 974

 info@co2capsol.com

 www.co2capsol.com